

Dear Clients: Thanks for choosing IBEST TCL SERIES temperature controller. Before installing and operating it, please read this instruction manual carefully. For any questions, please contact our sales or technical people immediately.

1.FEATURES

- PID temperature controller or ON/OFF control; built with SMT technology
- Auto tune function, fuzzy PID.
- Dual line 3 LED digit display: upper LED: red; lower LED: green
- Soft buttons, easily operate
- Optional input signals: thermocouple: K, E, J; thermo resistance: Pt100;
- Optional control output: Relay,SSR,SCR output.
- Alarm output: 1 high alarm
- Measuring accuracy: : $\leq \pm 0.5\%F.S \pm 1$ digit (under normal conditions)
- Optional instrument size: 48W×48H;48W×96H;72W×72H;96W×48H;96W×96H.(mm)
- Application ranges: food&beverage; oven, furnace, plastic extruder, chemicals processing, heating process...etc.(For temperature measuring and control)

2.ORDERING CODE

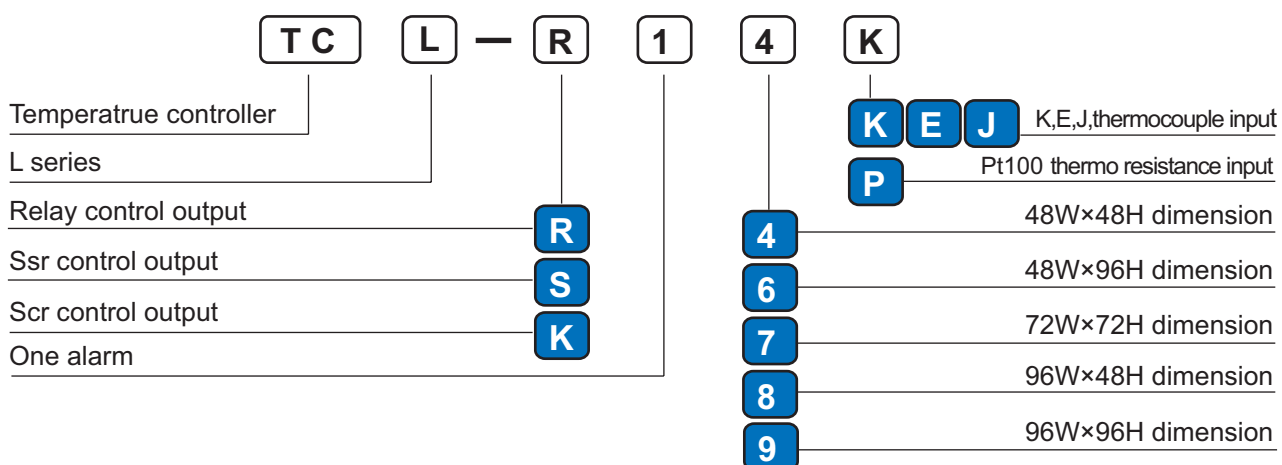

3.MODE

MODE				CONTROL OUTPUT	ALARM
TCL-R1□K	TCL-R1□E	TCL-R1□J	TCL-R1□P	Relay	One
TCL-S1□K	TCL-S1□E	TCL-S1□J	TCL-S1□P	Ssr	One
TCL-K1□K	TCL-K1□E	TCL-K1□J	TCL-K1□P	Scr	One

Notice: Input signals ---K: k thermocouple; E: E thermocouple; J: J thermocouple ;P: Pt100 thermo resistance

4.TECHNICAL SPECIFICATIONS

INPUT TYPE	Thermocouple	K	0~800℃
		E	0~600℃
		J	0~800℃
CONTROL OUTPUT	Thermo resistance	Pt100	0~99.9℃ or -200~800℃
	Relay	240V AC /3A	
	Ssr		
CONTRON TYPE	ON/OFF control / PI control / fuzzy PID		
MEASURING ACCURACY	0.5%±1digit		

IBEST ELECTRICAL CO.,LTD

OPERATION CONDITION	0~50℃ 45~85RH%/86~106KPa
INSULATION STRENGTH	AC 1500V 1 min / DC500V 50MΩ
POWER SUPPLY	AC 110V/220V (* The dimension 48W×48H is 85~260V AC)
DIMENSIONS	4:48W×48H / 6:48W×96H/ 7:72W×72H/ 8:96W×48H/9:96W×96H

5. PANEL ILLUSTRATION



6. OPERATION ILLUSTRATION

A. Function adjustment

Power on

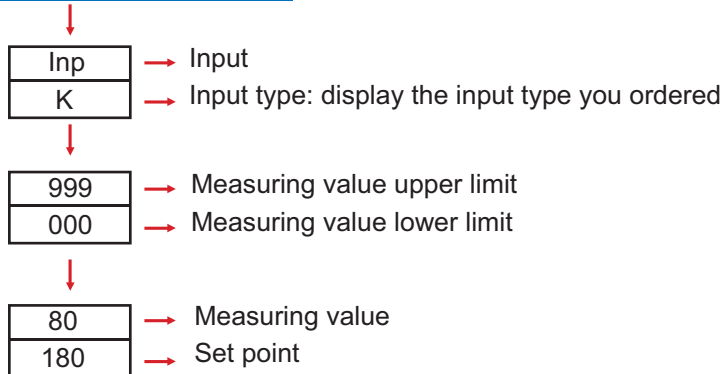

↓
Enter into measuring status

Set temperature

Press "↻" key, the upper LED display "SP"; lower LED display set value , press "▲" or "▼" to modify the value you need. Then confirm the value by press "↻" key again.

Control parameters

Press "↻" key for 5 seconds, the upper LED display the control parameters, the lower LED display the parameters value. To modify the parameters value, please press "▲" and "▼" key. Press "↻" key to confirm the value modified and then press "↻" to shift to the next parameter . If you want to escape the control parameters menu, please press "↻" key for 5 seconds; or no operation within 1 minutes also let the controller go back to measuring estate. The parameters list , please refer to page "T 3"

Auto-tune function

Press "▲" for 20 seconds , "AT" Lamp flash, the instrument begins Auto-tune . when the unit goes through 1 or 2 temperature waves, "AT" lamp goes out, Auto-tune finishes. Please keep the parameter value for future reference.

Notice

The red LED lower display "000", it means the thermocouple wire was wrongly connected; If the red LED upper display "000", it means thermocouple open circuit or the temperature suppressed the measuring scale.

B.Parameter list

PARAMETER	NAME	SPECIFICATIONS	SETTING RANGE	FACTORY SETTING
R _L	Alarm	Alarm output: AL 0 is high alarm AL 0 is low alarm ,rel alarm point: SP+AL	-200~800℃	50
AL				
r _t	Measuring valve correction	Correct the measuring deviation caused by the thermocouple and compensation cable	-100~100℃	0
rt				
R _r	Temperature overshoot restrain	To decrease "Ar" can decrease temperature over shoot ,when "SP" is changed ,"Ar" needs to reset ; when the value=0 ,the Ar=0.4℃	0~100℃	100
Ar				
P	Proportion band	"P" is bigger ,the proportion is less function ,the system gain is lower; if "P" is too big,the time to reach "set point" is very long,contrarily,"P" is too small,the temperature tends to fluctuate	0~400℃	30
P				
f	Control Cycle	Relay 20Sec External solid state relay or ssr controller,T=3Sec	1~100	20/3
T				
C _r	System constant	Relate the heating equipment's capacity,temperature increase time,thermocouple position, proportion band ...etc. usually for big inertial objects,cr should be bigger; When P≠0, Cr=0 is time proportion control	1~999	240
Cr				
L _c	Password setting	LC=0 All parameters can read and write LC=1 Only "SP" value can read and write others can only read LC=2 All parameters can read on	0~2	0
Lc				

7.DIMENSION AND INSTALLATION HOLE DIMENSION(unit: mm)

MODE	DIMENSION		INSTALLATION HOLE DIMENSION a × b
	W × H	C × D × L	
TCL-□14□	48 × 48	44 × 44 × 100	45 × 45
TCL-□16□	48 × 96	44 × 92 × 70	45 × 93
TCL-□17□	72 × 72	68 × 68 × 70	69 × 69
TCL-□18□	96 × 48	92 × 44 × 70	93 × 45
TCL-□19□	96 × 96	92 × 92 × 70	93 × 93

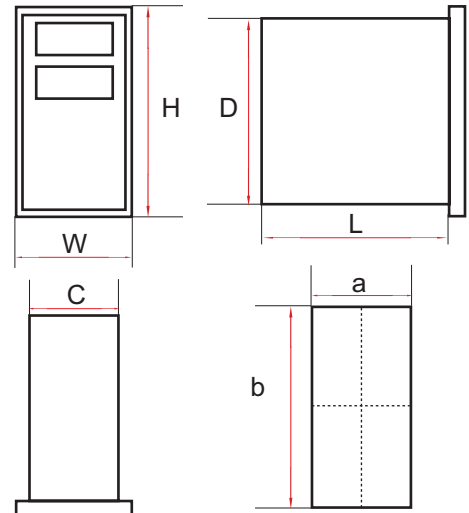

8.ELECTRICAL CONNECTIONS

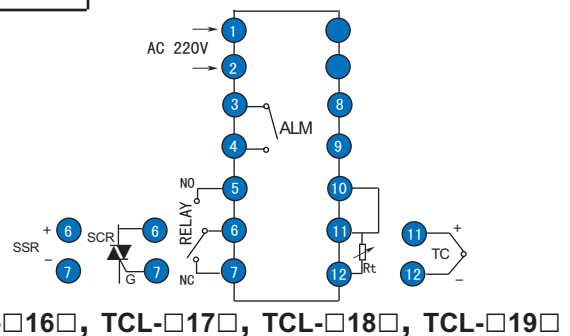
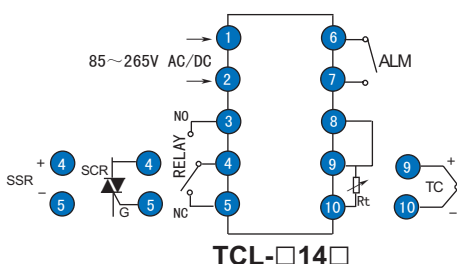

9. INSTRUMENT MAINTAINANCE AND STOCK

Before installing and using this instrument, please read this user manual carefully in order to operate the unit in the appropriate conditions to avoid any damage. Keep this user manual for future reference.

- When clean the instrument, make sure the power is at "OFF" status.
- To clean out the dust or dirt on the instrument screen, please use soft cloth or cotton paper.
- Do not touch the instrument screen by hard objects to avoid scratch of the screen.
- Do not use screw driver or hard pin to touch the soft buttons on the faceplate.
- From the date of shipping, if there are any damages or fault within 18 months, the factory is bond to maitain the units. But if the damages re couosed by inappropriate operation by use, the factory doesn's. The instrument should be stock in the dry ,non gas environment.